

PRODUCT WARNING

1. Do not lean diffuser during operation.
2. Unplug from mains power when filling or cleaning.
3. Do not empty water from the side which the air vent is located.
4. This appliance is not intended for use by children.
5. If the diffuser is accidentally knocked over during operation, water may enter the internal space.

If so, please unplug the diffuser, empty any remaining water and allow to dry for 3 days.

If any issues arise please contact your local retailer.

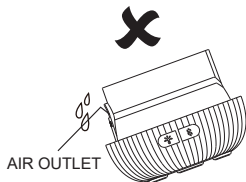
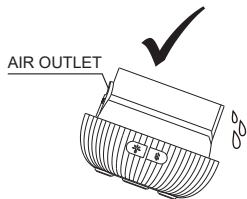

WORK FROM HOME Aromatherapy Set

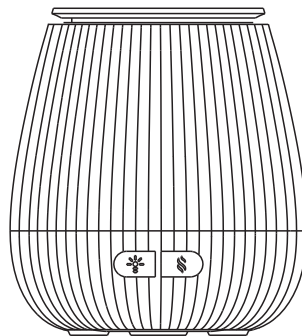

TABLE OF CONTENTS:

- A** Function
- B** Diffuser Setup
- C** Operations
- D** Maintenance
- E** Troubleshooting
- F** Warranty



FUNCTION

Your productivity is primarily reliant on your mental state. Setting up your diffuser each morning at your desk or in your office has almost the same effect as preparing a cup of coffee. It makes you feel ready, settled or even excited to get to work.

While powering through your workday, Alcyon essential oil diffuser can offer a multitude of health benefits, from concentration to anxiety relief. Be it our Day Awake blend or Relax & Calm blend, your choice of essential oil will be softly streamed into the air throughout the day keeping your mind sharp while helping you stay calm and stable to concentrate on your work.

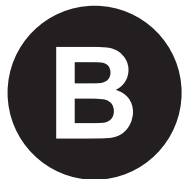

SPECIFICATIONS

Product Name: Alcyon Aroma Diffuser
Voltage: DC 5V
Power: 12 w
Water Capacity: 100 ml
Mist Output: 20+ ml/h
Duration: 4+hrs [approx.]
8+hrs intermittent mode
LED Effect: Colour Morphing
+ Selectable

Diffuser Operation			
☞ Mist Button		☛ Night-light Button	
First	Constant On	First	Colour Changing Mode
Second	Intermittent (15 sec on/15 sec off)	Second	Fixed Colour Mode
Third	Off	Third+	Single Colour
		Seventeenth	Light Off
		Hold	Turn Light Off Anytime

Location of Controls

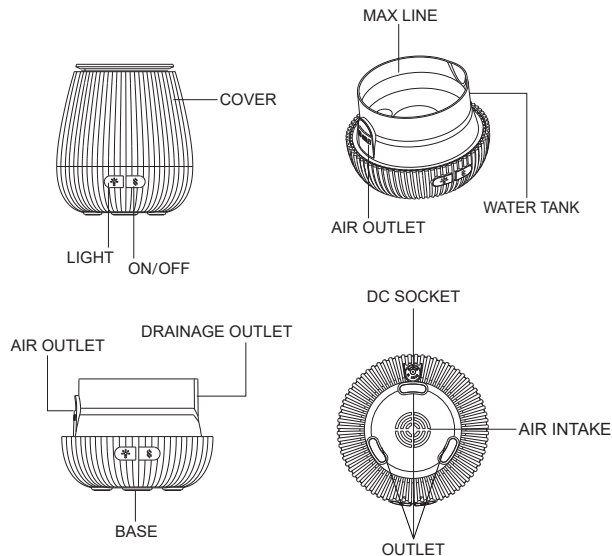



OPERATION

1. Place diffuser on a flat and even surface, clear of any loose or foreign objects.
2. Fill water tank to max level line - 100ml.
3. Add up to 3-6 drops of essential oils.
4. Replace cover & connect power.
5. Press the Mist Button for desired mist output.
6. Press the Light Button for desired light effect.



- 7 There is a quick flash of white light when power connected.
☼:
First press, the unit enters into continuous mist mode.
Second press, the unit enters into intermittent mist mode.(work 15s, stop 15s, recycle)
Third press, turn off the unit.
- 8 ✨:
First press, turn on the light and there are 7 colors changing automatically.
Second press, pause on current color.
Any further pressing the button to change the current color.
Light can work alone.(Long press can turn off the light.)



D

MAINTENANCE

To keep your diffuser in great working order, we recommend using Alcyon Diffuser Cleanser to clean regularly.

Alcyon Diffuser Cleanser - Revive and restore your diffuser like new. Most manufacturers recommend cleaning your diffuser every few weeks to remove impurities. Run for a 2-hour cycle and eliminate all the residual sediment and harmful particles left over from essential oils which impairs mist output and therapeutic performance. Alcyon Diffuser Cleanser makes it easy to keep your diffuser working like new so you can enjoy all its health benefits and get the full effect and pleasure from essential oil and aromatherapy.

To purchase please visit: www.alcyon.com.au



Directions:

Pour 30 to 50ml of diffuser cleanser into water tank of diffuser depends on its size. Add same amount of water to dilute the cleanser.

Run diffuser for 2 hours or until all cleanser in the tank has been diffused.

Remove any excess cleanser and rinse water tank thoroughly then wipe it clean with a soft cloth.

Resume normal use as per manufacturers operating instructions.

Ingredients:

Aqua, Potassium Lauroyl Sarcosinate, Potassium Cocoyl Glycinate, peg-6 Caprylic/capric Glycerides, beta-glucan, Dmdm Hydantoin, aroma

Caution:

For external use only. In case of contact with eyes, flush thoroughly with water. If eye irritation persists, get medical attention. Keep out of reach of children and pets.



TROUBLESHOOTING

Symptom	Possible Cause	Solution
NO MIST	Power not connected	Plug in power adaptor and press mist button to activate
	Insufficient water	Fill tank with water
	Too much water (100ml+)	Tip out excess water
	The mist outlet blocked by water droplets or oil build-up	Clean outlet vent cotton tip
	Poor performance due to dirty	Clean ultrasonic pad
	Cover not seated or sealed properly against base unit	Reseat cover



WARRANTY CARD

All Alcyon Ultrasonic Diffusers are covered by a limited one year warranty from date of purchase.

Date of purchase: ____ / ____ / ____
(please keep your receipt with Warranty Card as Proof of Purchase)

Should you be experiencing any issues with your diffusers, please visit www.alcyon.com.au or call 1300 882 332.
(please have your diffuser on hand when calling)

Terms and Conditions:

- A dated receipt is required as Proof of Purchase for warranty purposes.
- This warranty is for operational faults only, and does not cover issues such as breakages or faults arising from misuse.
- Any returned items from customers to Alcyon will be at the consumer's expense and must be accompanied with a RA (Return Authorisation) number issued by Alcyon. Unless a prior arrangement has been made.
- Any goods received without a RA number will not be accepted and returned to the sender.
- The determination of faults is at the discretion of Alcyon Australia, with the item to be either repaired or replaced.
- Return shipping from Alcyon to the customer is to be at Alcyon's expense.

Alcyon Australia
PO Box 50
LINFIELD NSW 2070

1300 882 332

info@alcyon.com.au